

**DIMENSIONS**

**No:S3AL0222030-00**

**MODEL: 80AL21.5 & 80AL22.2**

**1 Ø & 3 Ø**

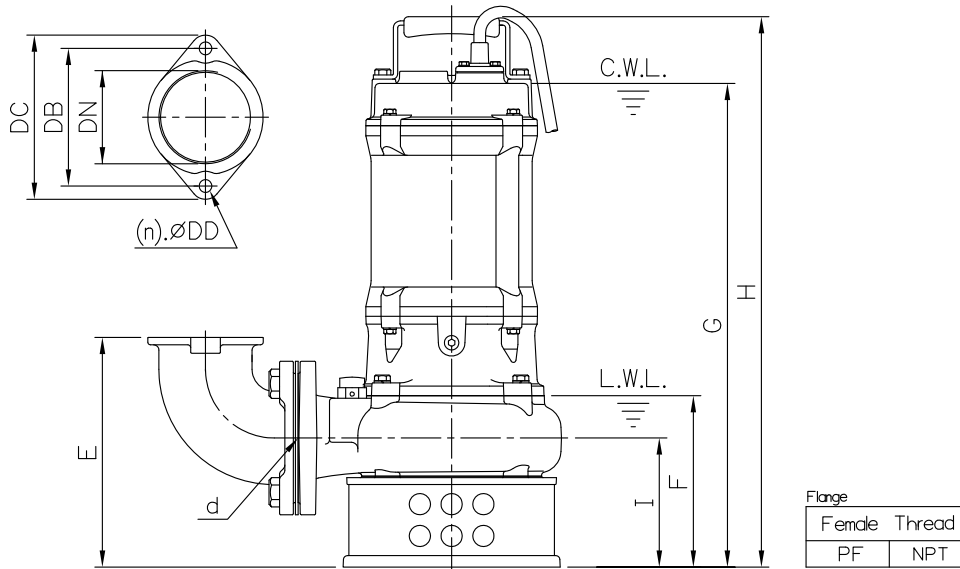
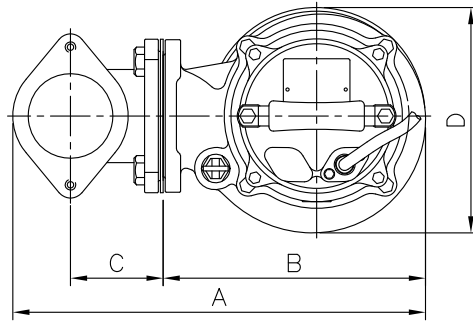

Dimensions—mm

Weight:kg

Model	d	A	B	C	D	E	F	G	H	I	WT1	Elbow (Flange) Set	DN	DB	DC	DD	(n)QTY	WT2
80AL21.5 1Ø	80	391	249	88	214	217	162	512	575	122	37	EB3-130	80	130	155	12	2	5
80AL22.2 1Ø	80	391	249	88	214	217	162	539	602	122	39	EB3-130	80	130	155	12	2	5
80AL21.5 3Ø	80	391	249	88	214	217	162	457	520	122	32	EB3-130	80	130	155	12	2	5
80AL22.2 3Ø	80	391	249	88	214	217	162	457	520	122	35	EB3-130	80	130	155	12	2	5

Dimensions—inch

Weight:lb

Model	d	A	B	C	D	E	F	G	H	I	WT1	Elbow (Flange) Set	DN	DB	DC	DD	(n)QTY	WT2
80AL21.5 1Ø	3	15 <sup>3</sup> / <sub>8</sub>	9 <sup>13</sup> / <sub>16</sub>	3 <sup>7</sup> / <sub>16</sub>	8 <sup>7</sup> / <sub>16</sub>	8 <sup>5</sup> / <sub>16</sub>	6 <sup>3</sup> / <sub>8</sub>	20 <sup>3</sup> / <sub>16</sub>	22 <sup>5</sup> / <sub>8</sub>	4 <sup>13</sup> / <sub>16</sub>	82	EB3-130	3	5 <sup>1</sup> / <sub>8</sub>	6 <sup>1</sup> / <sub>8</sub>	1/2	2	11
80AL22.2 1Ø	3	15 <sup>3</sup> / <sub>8</sub>	9 <sup>13</sup> / <sub>16</sub>	3 <sup>7</sup> / <sub>16</sub>	8 <sup>7</sup> / <sub>16</sub>	8 <sup>5</sup> / <sub>16</sub>	6 <sup>3</sup> / <sub>8</sub>	21 <sup>1</sup> / <sub>4</sub>	23 <sup>3</sup> / <sub>16</sub>	4 <sup>13</sup> / <sub>16</sub>	86	EB3-130	3	5 <sup>1</sup> / <sub>8</sub>	6 <sup>1</sup> / <sub>8</sub>	1/2	2	11
80AL21.5 3Ø	3	15 <sup>3</sup> / <sub>8</sub>	9 <sup>13</sup> / <sub>16</sub>	3 <sup>7</sup> / <sub>16</sub>	8 <sup>7</sup> / <sub>16</sub>	8 <sup>5</sup> / <sub>16</sub>	6 <sup>3</sup> / <sub>8</sub>	18	20 <sup>1</sup> / <sub>2</sub>	4 <sup>13</sup> / <sub>16</sub>	71	EB3-130	3	5 <sup>1</sup> / <sub>8</sub>	6 <sup>1</sup> / <sub>8</sub>	1/2	2	11
80AL22.2 3Ø	3	15 <sup>3</sup> / <sub>8</sub>	9 <sup>13</sup> / <sub>16</sub>	3 <sup>7</sup> / <sub>16</sub>	8 <sup>7</sup> / <sub>16</sub>	8 <sup>5</sup> / <sub>16</sub>	6 <sup>3</sup> / <sub>8</sub>	18	20 <sup>1</sup> / <sub>2</sub>	4 <sup>13</sup> / <sub>16</sub>	77	EB3-130	3	5 <sup>1</sup> / <sub>8</sub>	6 <sup>1</sup> / <sub>8</sub>	1/2	2	11

C.W.L.:Continuous Running Water Level WT1:Pump Weight(Without Cable)  
 L.W.L.:Lowest Running Water Level WT2:Elbow Set Weight